



QUEST 2000
2 FLAVOR POST-MIX
JUICE DISPENSER



FEATURES:

- Frost-free refrigeration compartment accommodates frozen, ambient or aseptic concentrate containers
- Large 8 lb ice bank provides cold drinks during peak demand
- Patented mixing system delivers consistent quality finished drinks
- Narrow foot print conserves counter space
- Optional lighted merchandiser promotes impulse sales and brand recognition
- Contemporary styling is a combination of attractive gray plastic and sturdy stainless steel
- Modular component design simplifies service and sanitation
- Push button or portion control dispensing is available

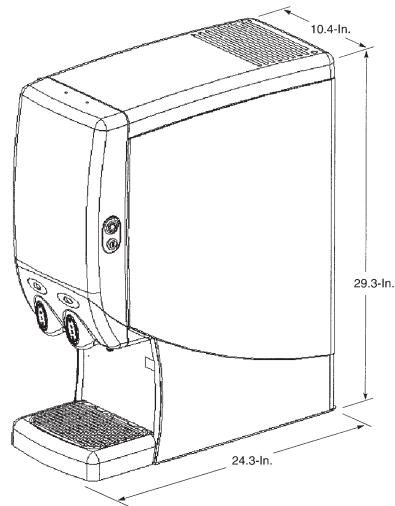

PART NUMBER	DESCRIPTION
721542120	Quest 2 Flavor Push Button 115 V / 60 Hz
721542157	Quest 2 Flavor Push Button , Non-Flush, No Sold Out, Non-Illuminated 115 V / 60 Hz
721542119	Quest 2 Flavor Portion Control 115 V / 60 Hz
721542106	Quest 2 Flavor Push Button 230 V / 50 Hz
721542108	Quest 2 Flavor Portion Control 230 V / 50 Hz
729011004	Extended Panel Kit for Pitchers/Carafes
720500066	Refillable Concentrate Reservoir (4) 3.5 L
729011153	Cup Locator
729011126	Bag-In-Box Option Kit
720601323	Syrup Separator

TECHNICAL SPECIFICATIONS:

DESCRIPTION..... 115 volts, 60 Hz
230 volts, 50 Hz

REFRIGERATION..... Hermetically sealed system, R-134a refrigerant 6.2 oz (175 g)

ICE BANK 8 lb

CABINETRY..... High impact plastic cabinetry with stainless steel front panel

DISPENSER DIMENSIONS 29.3"H x 10.4"W x 24.3"D (74.4 cm x 26.4 cm x 61.7 cm)

WEIGHT..... Dry: 96 lb (43.5 kg)
Operating: 136 lb (61.7 kg)
Shipping: 120 lb (54.4 kg)

RECOMMENDED CLEARANCE .. Back: 4" (10.16 cm)
Top: 12" (30.48 cm)

WATER CONNECTION 0.375" (.95 cm) SAE male flare SAE fitting on dispenser

CONCENTRATE STORAGE..... 2 - 3.5 L bottles

WATER SUPPLY REQUIREMENTS..... 50 psi (3.4 bar) recommended dynamic

OPERATING PRESSURE..... 80 psi (5.15 bar):
Max static pressure
20 psi (1.38 bar):
Min dynamic pressure

COOLING..... Four 5 oz drinks/min (148 mL) @ 75°F (24°C) ambient, 75°F (24°C) incoming water, and 40°F (4°C) concentrate without exceeding a 40°F (4°C)

FLOW RATE..... Adjustable water flow rate from 1-2.2 oz/sec
Handles 2 + 1 up to 7 + 1 concentrate

AGENCY LISTINGS:   

